

## **Cliff: the automatized zipper**

**Mohamad Zairi Baharom**

Eindhoven University of Technology

[m.z.baharom@tue.nl](mailto:m.z.baharom@tue.nl)

**Marina Toeters**

Eindhoven University of Technology

[marina@by-wire.net](mailto:marina@by-wire.net)

**Frank Delbressine**

Eindhoven University of Technology

[fdebres@tue.nl](mailto:fdebres@tue.nl)

**Chet Bangaru**

Eindhoven University of Technology

[c.bangaru@tue.nl](mailto:c.bangaru@tue.nl)

**Loe Feijs**

Eindhoven University of Technology

[l.m.g.feijs@tue.nl](mailto:l.m.g.feijs@tue.nl)

### **Abstract**

It is our strong believe that fashion - more specifically apparel - can support us so much more in our daily life than it currently does. The Cliff project takes the opportunity to create a generic automatized zipper. It is a response to the struggle by elderly, people with physical disability, and ladies who have problems zipping the back-zipper dress. An iterative “research through design” approach was applied (Toeters et al., 2012) to develop a working mechanism and identify the important factors to generate efficient traction mechanism. In between the iterations, the stakeholder and user feedback obtained from exhibitions has been used for the next iterations, which then led to the miniaturization of the Cliff prototype. The development progress of Cliff shows the tremendous potential of developing a generic automatized zipper, and it might be one of the approaches towards the “future of fashion” (Dunne, 2010). Problematic is that wearable systems are almost exclusively discussed with a functional focus. The functional benefit is entirely lost if a user refuses to adopt the technology because of social factors argues Dunne (2014). During the next steps, *Visual Perception Aesthetics* (Dunne, Profita and Zeagler, 2014), *Dynamic Functionalities* (Seymour, 2008), and *Cliff’s Ease of Use* (Starnier et al., 1999) must be reconsidered depending on its context of use. It is crucial to ensure users could positively perceive and use the Cliff as an assistive device for the zipping and unzipping process. With this paper, we hope to share tools and insights to enlarge the social engagement of the fashion industry by product innovation.

### **Keywords**

Automatized zipper, fashion, technology, wearables, assistive device.

### **Article classification**

Research paper

ISBN: 978-989-20-7053-7

## **INTRODUCTION AND MOTIVATION**

Garments are essential: no one forgets to get dressed before going outside. The clothes are worn so close to the body they are perceived as very intimate. Both make clothes highly valued and relevant products. Fashion pretends to be on top of newness but mainly changes on colours and shape. Fashion-oriented design encourages ingenuity, imagination and innovation (Walker, 2012), which are crucial elements in pushing forward technological and social progress (Pan et al., 2014). It is our firm believe that fashion – more specifically apparel – can support the wearer so much more in our daily life than it currently does.

A zipper can be seen on various kinds of garments such as on the jacket and dress. Even though the zipper is a simple device to be operated, not everybody can perform the zipping and unzipping process efficiently and independently. Therefore, the motivation to develop Cliff, which is an automatic zipper, is a response to the struggle of the few groups of people such as the elderly, people with physical disability, and ladies who have problems zipping a back-zipper dress. Hopefully, this innovative idea and invention could create value, which in turn might lead to the greater benefits for society to ease the zipping and unzipping process. With team skills in mechanical engineering, fashion design, and prototyping, Cliff has been developed. Cliff is an attempt to research how innovation can help developing supportive fashion. Fashion has to innovate, and garments have to become more relevant and assistive for its users. Therefore, to research this as concrete as possible we took one design opportunity, the automatized zipper. This paper will discuss what are the essential factors to be considered in the development of the automatized zipper to ensure users could positively perceive and use it as an assistive device for the zipping and unzipping process.

Besides researching the essential factors for the users, we also need to tackle the technical issues and how the iterative research through design method (Toeters et al., 2012) could be beneficial for this project. The most challenging technical part is on how to develop a generic and universal type of an automatized zipper and to define the significant factors to produce an efficient traction mechanism for the Cliff. Additionally, this paper will also look at how the iterative research through design method could assist and benefits the development of the miniature prototype of the automatized zipper. Overall, this paper reflects on the early stage development process of Cliff and discusses next development steps. We hope to share tools and insights to enlarge the social engagement of the fashion industry by product innovation.

## **HISTORY: FROM CLASP LOCKER TO ZIPPER**

Formerly known as a clasp locker, a zipper is commonly used for binding the edges of an opening of fabric or other flexible material, like on a garment for example. It can join two pieces of fabric together. The chronology of zipper invention begins back in 1851, when Elias Howe, who invented the sewing machine, received a patent for an automatic, continuous clothing closure (Howe, 1851). The first person to design, conceive the idea of slide fastener and develop the working zipper is Whitcomb L. Judson

(Judson, 1893), an American inventor from Chicago, back in 1893. Whitcomb's patent use the word 'clasp locker' instead of using the word 'zipper', which is a complicated hook-and-eye shoe fastener (Judson, 1893; Shaw and Grall, 2003). In 1913, Gideon Sunback who was an electrical engineer designed the modern zipper and patented a design entitle 'separable fastener' in 1917 (Sundback, 1917). The design increased the number of fastening elements, introduced two-facing rows of elements that pulled into a single piece by the slider and also increased the opening for the elements guided by the slider. In 1937, the B.F Goodrich company then decided to use Gideon's fastener on a rubber boot and named the device as 'zipper' (Ansun Multitech, 2015).

### THE ZIPPER MECHANISM

Figure 1 shows the zipper closing mechanism. As the slider moves up with speed ( $v$ ) in Figure 1(a) and the zipper tape is fixed, it pushes the elements to enter the slider throat together at specific angles. The force ( $F_w$ ) extended by the lower wedge is perpendicular to its movement direction. As the tape moves through the slider, the lower wedge inclined edges pushed the elements towards each other and latched into a gap on the opposite side. It is the same process as in Figure 1(b) when the zipper tape is being pulled from the bottom and the slider is fixed. This condition will also complete the zipper closing operation. When the slider has been pulled down as in Figure 2(a) and the tape is fixed, the diamond pushes against the slanted edge of the elements and pivoting each element away. Then, both sides of the zipper are detached. This operation can also be done by fixing the slider and pull both sides of the zipper tape as shown in Figure 2(b) (Baharom et al., 2016).

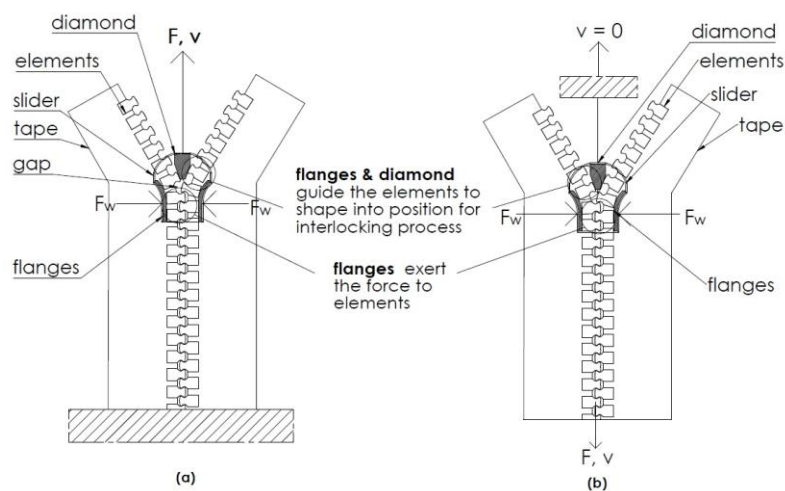

Figure 1. Zipper closing mechanism diagram.

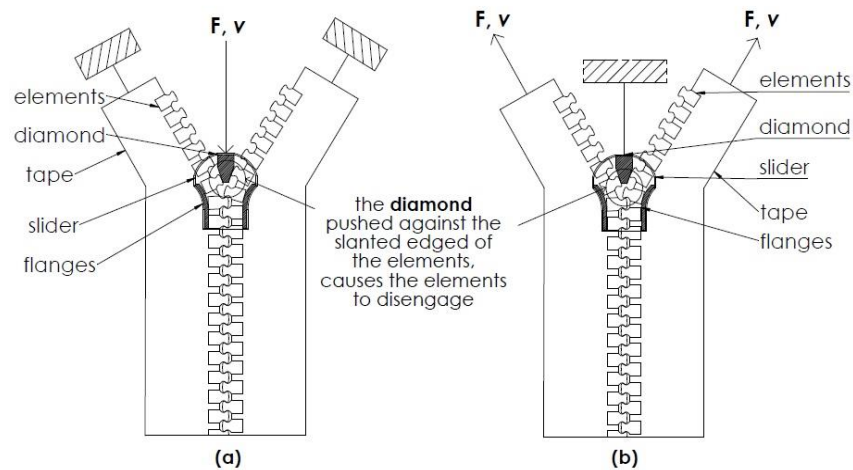

Figure 2. Zipper opening mechanism diagram.

### **INSPIRATION: ZIPPERBOT AND ACTUATION IN WEARABLES**

The development of an automatized zipper could be useful as an assistive device to assist anybody who has problems using a zipper. This project was inspired by Adam Whiton from Massachusetts Institute of Technology (MIT), who built the first robotic zipper known as the Zipperbot (Whiton, 2015). The structure of the Zipperbot did not use the slider of the zipper to zip or unzip. Therefore, this newly designed Cliff tries to remain the zipper structure as it is and develops a generic and universal type of robotic zipper. Besides that, the inspiration of this project also comes from an article written by Marina Toeters and Loe Feijs on actuating movement in refined wearables (Toeters and Feijs, 2014). The Cliff could be another new device in the world of wearable technology and the “future of fashion” (Dunne, 2010).

### **APPLICATION OPPORTUNITIES FOR AN AUTOMATIC ZIPPER**

The back closures are a conventional fastening method on garments designed for all ages such as dresses, skirts and blouses. A back closure system means that the wearer will have to fasten their garment at the rear, with the use of a zipper, hook-and-eyes or buttons. This kind of feature of a garment’s design comes for stylistic reasons. It allows for a solid unbroken front to the garment that is uncluttered by fasteners. Fashion designers often favour this back closure for couture and formal wear, where the aesthetical value is essential. However, the back closure still has its advantages and drawbacks. A back closure dress offer the wearer a quick enter and exit from the garment from the rear side, especially for the dress that is closely fitted and does not stretch. For example, a high necked-garment can be quickly pulled on without disturbing the wearer’s hair with the opening at the back. The most obvious drawback of the back closure is the difficulty to reach the middle of the wearer’s back and manipulate the fasteners to close their dress. Therefore, the wearer might need assistance to donning or doffing their dress. If they keep trying on their own, it could be time-consuming to wear or remove the dress.

Dressing and undressing difficulties are also seen for people who are sick or have a physical disability. These people who are unable to zip or unzip themselves will require assistance from others to perform the task. Individuals with upper limb reduction deficiencies (ULRD) for example will have difficulties to use the zipper. In a study conducted by Vasluian et al., more than 50% of the youngsters with ULRD reported having problems to perform their daily life self-care activity of dressing and undressing and tying their shoelaces (Vasluian et al., 2014). This group of people who live with only one arm, or with no arm, will have significant difficulties of executing their daily task. Besides that, individuals with myotonic muscular dystrophy (Balon, 2011), a kind of degenerative disease which limits the use of hands can get some benefits too from the development of this automatized zipper. Most of our daily activities or tasks require the use of both hands at one time. In a study related to patients with Parkinson's disease (PD), few modifications have been suggested to change their approach to open or close the zippers (Mady and Atiha, 2015). PD patients will experience some dexterity on their body systems, activities and the fine motor development. They usually have issues with finger dexterity which will reduce their ability to use the zippers or fasten button themselves. Automatic zippers could also become useful in interior solutions like for instance curtains. But they won't be discussed in this paper, as it is not in the interest of this conference.

#### **AN ITERATIVE “RESEARCH THROUGH DESIGN” (Toeters et al., 2012) APPROACH**

By making prototypes, designers simultaneously discover how to approach the problem at hand. In some situations, it can be more efficient than first drafting the system on paper. Through an iterative process, it is easier to approach complex design challenges using multiple cycles. The perfect solution doesn't have to happen in the first attempt. The act of designing is not only a thought process but also a generator of knowledge. Creating tangible solutions that can be experienced are essential throughout the design process to validate ideas and to guide further developments. Research through design involves making and reflection. It allows creating a dialogue with the material and helps the designer and stakeholders to envision future applications with the prototypes. Touching materials and demonstrators are also important to talk to (potential) stakeholders and to convince the people in the boardroom (Toeters et al., 2012). The next chapter will discuss multiple prototypes that were created in Cliff's iterative research through design process.

## PROTOTYPING: THE FIRST THREE ITERATIONS

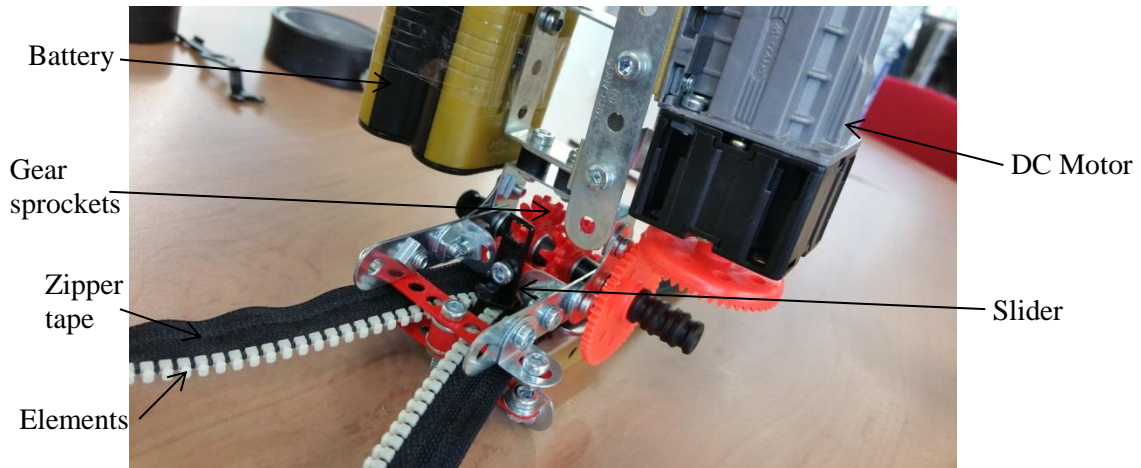

Figure 3. First iteration prototype (Meccano)

*Iteration 1:* After understanding the physics and mechanics of the zipper, this project begins with exploring the potential traction mechanism using Meccano (Marriott, 2012). Meccano is a toy consisting of a set of plastic and metal parts which enables the building of working models, mechanical devices or prototypes. The aim for this first iteration is to identify the potential mechanism that can generate traction to move the zipper tape since the slider is fixed on the Meccano structure. The main challenge here is to develop a generic and universal type of traction mechanism which can be used in all types of zippers. After two months of trial, the first iteration of this project works. Figure 3 shows the first iteration prototype made of Meccano. The direct current (DC) motor and battery is placed on top of the rotating wheel. It used two gear sprockets kind of wheels as traction mechanism on both sides of the tape to establish the uniform distribution of normal force acting towards the zipper tape. The gear sprocket wheel from top and bottom side of the prototype make contact on the zipper tape surface and generate traction. The gear teeth grab the zipper tape in between the top and bottom wheels. This mechanism managed to drive the zipper tape in the forward and backwards direction for the zipping and unzipping process.

*Reflection on iteration 1:* The weaknesses of this first iteration prototype are on its stability. It generates vibrations during its operation. Secondly, the gears used to connect the DC motor and the rotating wheels could easily misalign. Besides that, this first iteration is too big in size, too heavy and the metals look. Therefore, it is not suitable to be attached to garments.



Figure 4. Second iteration prototype (Meccano)

*Iteration 2:* Figure 4 shows the second iteration prototype also with Meccano. This second iteration aimed to stabilize the overall structure from the first iteration. It is essential to evaluate and observe correctly why this mechanism works. The DC motor has been placed on the side of the rotating wheels.

*Reflection on iteration 2:* The movement and performance of this second iteration prototype are much better than the previous one. We found that the gear sprocket from the top and bottom side of the prototype make contact with the zipper tape surface and generate traction. The gear teeth grab the zipper tape. The overall size of this second iteration prototype is still too big to be placed on garments, and it still looks metal like.

The second iteration prototype has been exhibited in two exhibitions in Eindhoven in November 2015 which are the Smart Homes exhibition (Smart Homes, 2015) and Liever Thuis exhibition (Liever Thuis, 2015). Based on these two exhibitions, most of the people gave positive feedbacks to this robotic zipper prototype. They showed their interest in this project and said that this device could be beneficial to everybody who has problems to use normal zippers independently. Regarding the functional requirements, most of the visitors could clearly envision the primary function provided by this device, which is to do the zipping and unzipping process automatically. Regarding non-functional requirements, which express the qualities that this device should have, they are mainly focused on the size of the final piece. The majority of the respondents wants it to be small and handy with a minimum thickness of the inner side that is in contact with human skin. This project also showed to a group of VITALIS caregivers (Vitalis, 2016), a company who runs a care home for elderly. This company also develops tools to extend independent lifestyles for the same target group. Their opinion on this project is this project is incredibly fresh and could assist elderly to dress and undress by themselves. They also mentioned that the final piece should be not too small and easy to be placed on the garments. Besides that, the elderly also have shown their interest in this project. They found that this project is fascinating and could help them to zip their jacket because they usually have problems dealing with the small pull tab to pull the zipper slider.

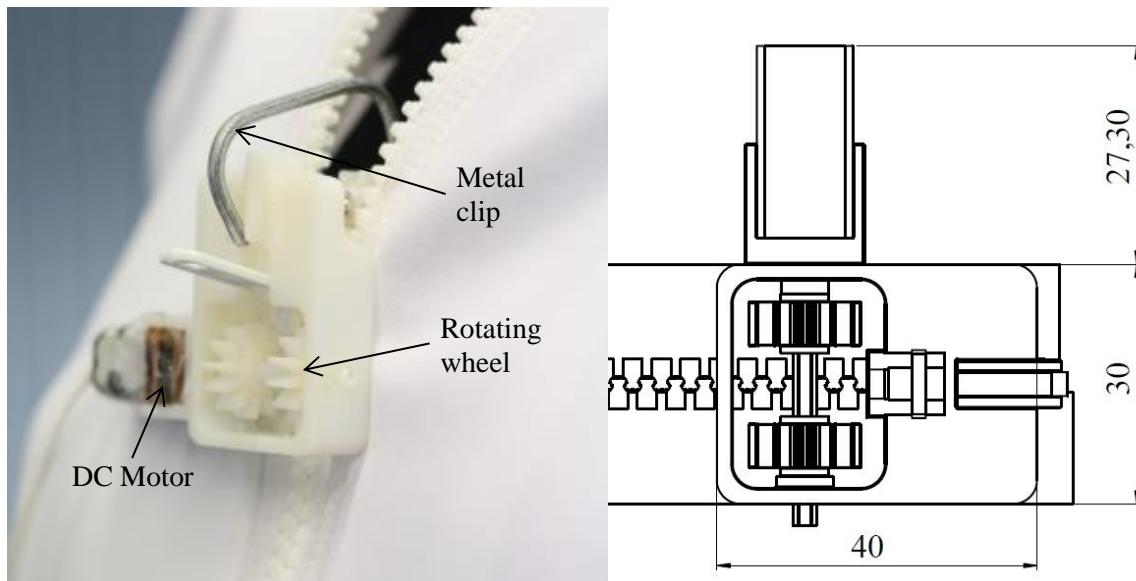

Figure 5. Third iteration prototype (miniature model) with dimension in millimeters (mm)

*Iteration 3:* Based on the feedback obtained from the Smart Homes and Liever Thuis exhibitions (Liever Thuis, 2015; Smart Homes, 2015), along with the understanding of the mechanism from the first and second iteration, we continued the development of this robotic zipper into the miniaturization stage. At this juncture, we are trying to produce a smaller automatized zipper. The third iteration target is to develop a miniature model that can run on a jacket designed by Marina Toeters (Toeters, 2015). The rapid prototyping process has been used to produce this miniature model of the robotic zipper (Kuusk et al., 2012; Price and Lewis, 2015; Toeters et al., 2012; Zorriassatine et al., 2003). It used ABS plastic as the rapid prototyping material. Showing in Figure 5 is the third iteration prototype on a jacket. As can be seen, the DC motor was placed on the side of the chassis. The motor shaft is parallel to the rotating shaft of the traction wheels. The selection process of this DC motor has been made after a kinematic analysis to determine the suitable DC motor that can drive this robotic zipper based on the forces on this system (Baharom et al., 2016). The design for this third iteration functions like a detachable piece, which separates the top and bottom chassis of the Cliff. Both sides of the chassis joined through a screw, slotted in the middle, which allows it to act as a clip. It offers flexibility where you can quickly put on and take off the Cliff from your garments. The other significant finding on this third iteration is the need of a sufficiently high normal force to clamp the top and bottom chassis together, and ensure the fabric engage between the two rotating wheels. It is essential to ensure traction. Therefore, a metal clip is slotted in at the front of the Cliff as can be seen in Figure 5. This metal clip provides the normal force to the top and bottom chassis, to ensure the fabrics of the jacket are in contact with the traction wheels, thus generates friction and produce excellent traction for the zipping and unzipping process.

*Reflection on iteration 3:* Even though this third iteration prototype works well, there are still a few aspects which need to be improved. The DC motor position on the side of the chassis causes imbalance during the movement, and could lead to misalignment of the rotating wheels. Moreover, this third

iteration prototype also does not include a switch and battery, attached to the structure as a single complete unit.

This third iteration is a significant achievement of this project since we managed to develop the Cliff in a much smaller size (40 x 57.3 x 25 mm), compared to the previous two early iterations. Marina Toeters has given her feedback on this success. She says (Toeters, 2016):

*“I’m impressed with the latest development of the Cliff, which it is currently a working prototype that suitable to apply in garments. Numerous technical, material and functional iterations are being made. From the big size, towards the tiny system as it is now. For the upcoming iteration, the clamp function is to be developed and adjusted, applying pressure (possibly via a steel structure or coil spring). The battery – 2 times the tiny 3.7V batteries will equal to one battery pack of 7.4V) and, if needed, a printed circuit board (PCB) has to be integrated into the main body of the zipper system, a switch to be added on top of the system, left side (to be handled with the right hand) and the motor to be moved below vertical against the zipper. The size of the system is already a good, small size for the forthcoming show. Styling work on the front side of the casing (rounded edges, transparent casing to avoid obstruction but keeping mechanism visible). Make sure to integrate the wires as neat as possible”.*

## **SOCIAL WEARABILITY**

The feedbacks received from Marina Toeters (Toeters, 2016) raised a few important issues such as on the power and aesthetics. Power is still is a significant problem in most smart clothing and wearables application (Dunne, 2010). A small size of the battery with sufficient power is usually the most preferred by designers. Secondly, the aesthetics part is also a crucial element to be looked in. The aesthetics may, in fact, become the key elements for consumer or users adoption decision (Dunne, Profita, Zeagler, et al., 2014). The styling work on the front side (rounding edges) as highlighted by Marina is an excellent point to be looked at. The curved shapes may be perceived as more comfortable and ergonomic since the Cliff bottom side was placed under clothing and this is more easily read as a protrusion of the body surface rather than a concealed technology (Dunne, Profita, Zeagler, et al., 2014). Dunne et. al (2014) also mention that a wearable device worn under clothing may produce a bump or distortion to the body shape, which may or may not be obviously attributable to something being worn under the clothes (Dunne, Profita and Zeagler, 2014). Therefore, the thickness of the bottom side of the Cliff should also be considered as it possibly produces a bump and distortion to the body shape. The bottom side thickness is influenced by the diameter of the rotating wheels. The Cliff prototype is using two rotating wheels to generate traction and move the zipper. Therefore, to reduce the thickness of the bottom side is first to deal with the traction mechanism or a different kind of wheels which might be potential to be used.

If the aesthetics part is not well-taking care of, it could cause the Cliff to be abandoned like other fully functional or high-performing devices which often neglect the importance of aesthetics values (Dunne, Profita and Zeagler, 2014). Based on all these feedbacks and the social wearability aspects: how

innovations on the body be accepted by the target group? Therefore, the development of this automatized zipper enters its fourth iteration process which will be explained in the next subtopic.

### THE CURRENT CLIFF PROTOTYPE

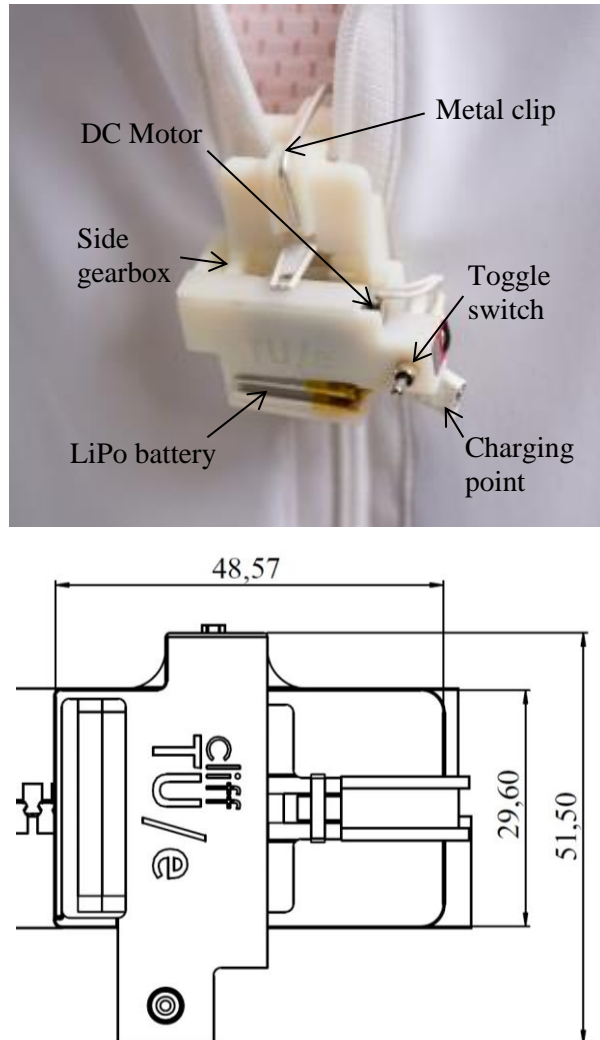

Figure 6. Fourth iteration prototype (miniature model with battery and switch in a single unit) and dimension in millimeters (mm)

*Iteration 4:* Figure 6 shows the fourth iteration of the Cliff. The construction of this iteration was based on the feedback received from Marina Toeters (Toeters, 2016) and problems identified from the third iteration. The aim for this iteration is to build a single unit of the Cliff, with the switch and battery attached to it. The DC motor is placed on top of the wheels and connected through a vertical side gearbox. Two pieces of 3.7V LiPo battery are used to power the 6V DC motor, and there is also a battery charging point installed. The installation of the charging point is the reflection on middle ground care and maintenance requirements which the consumers are accustomed to given types of maintenance interaction with the technology such as the charging part (Dunne, 2010). A three poles toggle switch is used to control the system as the switch provides functions to the ON(unzipping) – OFF – ON(zippering).

This fourth iteration introduces a much smaller and neat shape clip to provide normal forces on top and bottom chassis, thus clamping both sides. The normal force is vital to ensure the jacket fabric in between the rotating wheels is in contact with those wheels and generate excellent traction. The ABS plastic material of rapid prototyping again used as the material for the structure of this fourth iteration prototype.

*Reflection on iteration 4:* This fourth iteration prototype works well, but not for an extended period of time, due to reliability issue. The problem is the gears on the side gearbox are too small. Since we printed those gears using the 3D printer, the material is not strong enough to perform the operation, and the gears break. The mechanism of this iteration works nicely. Therefore, the construction of the next iteration will use other materials instead of the 3D printer plastic material. Lightweight metals could be an option to replace this plastic material. However, choosing the material need to be properly done since technological components might be stiffer and heavier, which when integrated into clothing, could create swinging masses or digging edges on the clothing or the body (Dunne and Smyth, 2007). This condition will result in discomfort and restricted movement or fatigue for the user.

## **VISUAL PERCEPTION AESTHETICS**

De Long et. al discussed the expressive and referential characteristics as shown in Figure 7. The expressive characteristics are the direct features of the form itself such as the visual elements of shape, colour and texture. The referential characteristics are interpreted by the viewer itself (DeLong, 1998). In some ways, the expressive characteristics are less open to being interpreted by the user, which it tends to play an innate response. For example, bolder colours being perceived as aggressive elements and flowing shape is seen as softer and gentler. Starner et al. found that the expressive characteristics of a wearable computer concerning colours were often received by the most viewers (at the time) as a medical device (Starner et al., 1999). The alteration of the head-mounted display has changed the device into a new referential association as been studied by Starner et.al. Most viewers interpreted the white or light-coloured wearables devices as the medical device, while grey or black devices perceived as the consumer products. This is one of the examples on how the colour selection influences the visual perception aesthetics of wearables devices.

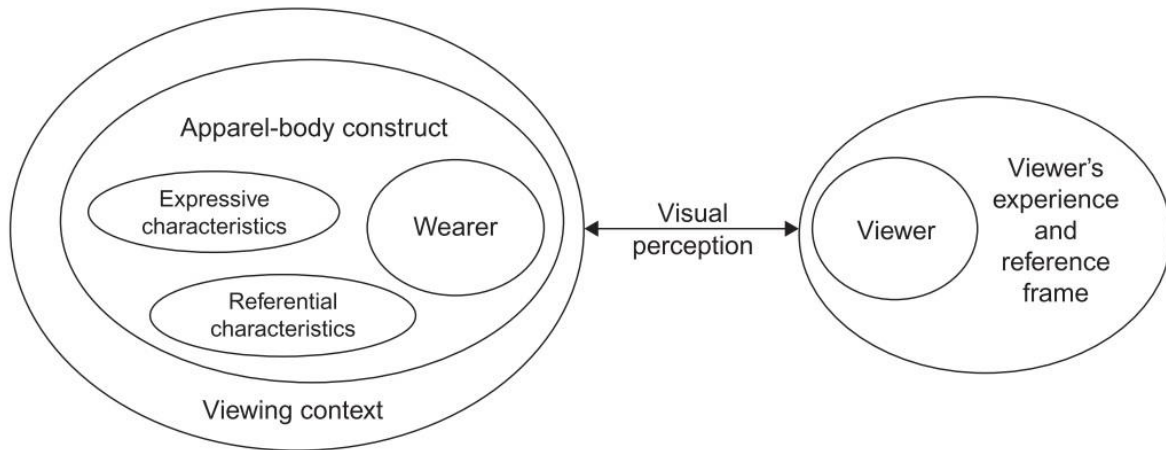

Figure 7. Visual Perception Aesthetics (Dunne, Profita and Zeagler, 2014).

The referential characteristics are the form that the viewer understands as related to something which is outside of the shape such as the brand logo or a symbol of an occupational role like a badge. Therefore, the referential characteristics depend more on the viewer or user experiences and prior knowledge. The introduction of a small “Cliff” and TU/e (Technische Universiteit Eindhoven) logo engraved on the top of the chassis also attracted a few people during the show in Amsterdam back in April 2016 (Holst Centre, 2016). It is a kind of referential characteristics which most of them asking about this product which is still early in the research stage.

The importance of form and colours are the example elements that represent the visual perception aesthetic. Starner et.al agree that the shape and colour could assist to communicate the machine’s or devices purpose and help frame the socially accepted uses of a given tool (Starner et al., 1999). Cliff is currently using rotating wheels which look like a gear sprocket. If the whole structure of the Cliff is not fully covered, it could bring bad perceptions from the user. They might see the spiky wheels itself as a kind of dangerous part. The shape of the housing on top and bottom side of the Cliff could be the first impressions of the user on how the device could also be accepted. Therefore, the right shape and colours are crucial to ensure that it can be socially accepted as a wearable piece instead of just an assistive device for the zipping and unzipping process.

## DYNAMIC FUNCTIONALITIES



Figure 8. The Cliff at 10th Year Holst Center Anniversary Symposium, Amsterdam. (Photograph by Jonas-Briels Photography).

The fourth iteration prototype as shown in Figure 8 was exhibited at the 10<sup>th</sup> Year Holst Centre Anniversary Symposium in Amsterdam, on 14<sup>th</sup> April 2016 (Holst Centre, 2016). The Cliff was worn by a model on the jacket designed by Marina Toeters. A lot of feedback was received from professionals who attended the event. One of it is from Craig McEwen, from the Sales and Business Development of ShinEtsu Micro5i, San Jose, USA. He told me *“the Cliff could be beneficial to lots of people and also useful for fashion”* (McEwen, 2016). Another expert comment comes from Magdalena Wasowska, the Divisional Director, Technology and Software Centre of SONY Europe. She mentioned *“the Cliff is a magnificent and useful project. You can add thermal sensor as an additional feature, which could make Cliff automatically open or close the garment, based on the human body temperature. You should also try to reduce the size of the Cliff and communicate with the human body through the feedback system. For the promotion, you should work on a good commercial video for marketing purposes”* (Wasowska, 2016). Reflecting on this comments, it describes the importance of dynamic functionality as the suggestion of adding a thermal sensor in the Cliff is an option to render the existing static functions to become vibrant and responsive (Dunne, 2010; Dunne et al., 2002). Dunne et. al explained an example of protective features, like the thermally protective garment such as winter coat is traditionally provides some degree of thermal insulation. The amount of the insulation will remain the same in any surroundings or conditions. If the weather suddenly changes, or the user moves to indoor, the winter coat will become uncomfortable to wear. Traditional technologies will just allow the wearer to unzip the winter coat, push up the sleeves, or remove it entirely. However, using electronic technologies, the coat insulation can be replaced with heat-generating technology by using a sensor-driven heat-generating coat. This kind of technology can provide a dynamic level of thermal protection for different

conditions of the environment (Dunne et al., 2002). It also reveals the potential of the Cliff which can automatically open the coat zipper if the weather drastically change by embedded a thermal sensor into the system.

The dynamic functional aspect is one of the most important issues discussed in the wearable systems. It is usually explained regarding what the wearables do and how well they perform the task. The primary function of a dress is not only to cover our body or what the dress offers to the user regarding beautiful design, good fabrics or fashionable looks. It also involves how the dress communicates to the wearer and others. The feedback loop itself will create an active environment for any wearable. In the Cliff case, this device could also behave as an active system if sensors could be embedded in the system such as a thermal sensor. For instance, if your body is sweating, the Cliff could open the zipper automatically. Besides that, the Cliff could also be an active system to deal with different thicknesses of the fabrics. Different kind of fabrics such as silk, satin, cotton or even jeans will have different thickness. Therefore, the amount of normal forces and friction coefficient required to ensure the top and bottom rotating wheels to grab the fabrics is different. Hence, this situation will need an active actuating system to deal with it.

### **EASE OF USE**

The accessibility to the wearable device also needs serious attention. Quick access will tremendously increase the use of the device. The Zipf's principle of least effort states that people will select a strategy for action that ensures them that the minimum effort is required to reach the desired result (Zipf, 1949). Starner et. al mentioned that an informal rule was developed in his project that every function intended for daily use must consume less than two seconds to be accessed. Longer setup or teardown time for the interaction or accessibility of any devices will pose a significant barrier to usage (Starner et al., 1999). This matter will also be taken into consideration for the future development of the Cliff. A lower setup time to clip the Cliff on the zipper and easy accessibility and control interface will increase the usability of the Cliff.

## OVERVIEW OF THE PROCESS AND FUTURE WORKS

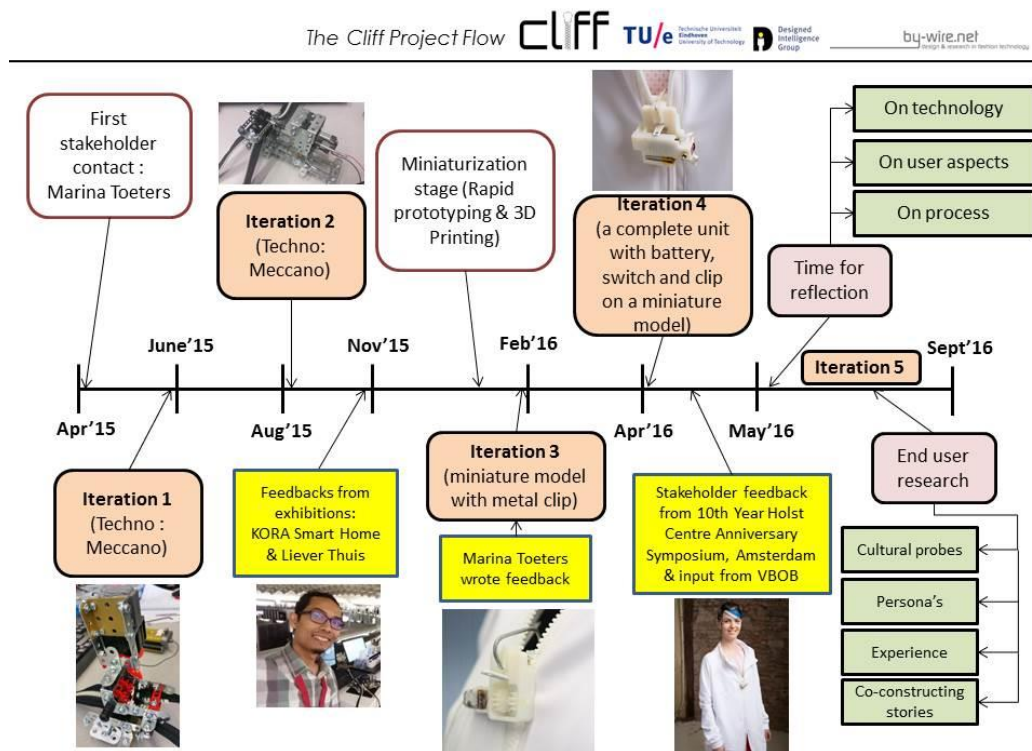

Figure 9. The Cliff project timeline review.

It's been almost one and a half year since the beginning of this project. Showing in Figure 9 is the Cliff project timeline review since the initial kick-off in April 2016. It begins with the first stakeholder input from Marina Toeters itself about the idea and inspiration to design an automatized zipper. Four iterations produced four prototypes during the first year of this project. In between those iterations, various feedbacks and comments were received from users and stakeholders. Improvements and modifications were made, based on the concerns raised by the user or stakeholder, and also from the problems identified during our discussion and review of the design. We are currently in reflection period. We are reflecting also the technology, user and process aspects. The end user research towards a specific focus group will be conducted. It is important to define a particular focus group and finding the right application of the Cliff.

Wearability is an essential element that needs to be considered seriously during this reflection period. According to Dunne et.al (2007), social wearability refers to the degree of comfort concerning physical, mental, emotional and social, which afforded by a body-mounted object or device, rather than the possibility of it being mounted on the body (Dunne and Smyth, 2007). In this context, a device that causes discomfort, or brings difficulties to the user to wear, is an unwearable device. An unwearable device is a device that will not be adopted by its user. Therefore, it is crucial to think about how this device is physically perceived by the wearer or the user. Several studies conducted on wearability have investigated the device-centric variables that contribute to wearability such as the physical shape (volume and contour), the body location of the device, the ability to move freely, and feelings of pain

or pressure (Gemperle et al., 1998; Knight et al., 2002). The benefits of any particular wearable devices will be lost if the user refuses to adopt the technology itself.

The development progress of Cliff shows enormous potential of developing a generic automatized zipper. It might also be the “future of fashion” in smart clothing or wearable technology when taking visual perception, aesthetics and its social aspects into account. For future works, the technology, user focus, and fashionability need to be improved. Dynamic functionalities (Seymour, 2008), and Cliff’s ease of use must be reconsidered, depending on its context of use. Every function intended for daily use must consume less than two seconds access (Starner et al., 1999). Unfortunately, we are not there yet, but we are actively working on this.

## CONCLUSION

This paper reflected on the early stage of the development process of Cliff, an automatized zipper. The aims of this product development are to identify complexities on different levels. By undertaking an iterative research through design process the problem definition and essence of the product qualities became clearer. We were able to unfold them one by one during different cycles by involving the user and stakeholder feedback in each following iteration. The most challenging technical part is on how to develop a generic and universal type of an automatized zipper. The first working prototype, which uses the kind of gear sprocket wheels as the traction mechanism, managed to materialize the intention to develop a generic automatized zipper. In the following iterations, the significant factors to produce an efficient traction mechanism for the Cliff, was identified. The chosen mechanism leads to the success of all four iterations. This achievement led to the development of the Cliff miniature model of a single unit system complete with a battery and toggle switch. The development progress of Cliff and received feedback shows the tremendous potential of developing a generic automatized zipper. It might be one of the approaches towards the “future of fashion”. Without the iterative research through design approach, applied throughout the Cliff development process, it is impossible to obtain such a deep understanding of this field and the technological opportunities for this project.

As previously stated, the user will lose the benefits of any particular wearable devices if they refuse to adopt the technology itself. The most important question here: What are the essential factors to be considered in the development of the automatized zipper to ensure users could positively perceive and use it as an assistive device for the zipping and unzipping process?

- *Visual Perception Aesthetics* and its social aspects have to be taken into account (Dunne, Profita and Zeagler, 2014). The product should avoid any stigmatisation. The right shape and colours are crucial to ensure that it can be socially accepted as a wearable piece instead of just ‘an assistive device’ for the zipping and unzipping process.
- On a conceptual level, Cliff’s *Dynamic Functionalities* (Seymour, 2008) have to develop further. This device could behave as an active system if any potential sensors could be embedded in the system such

as the thermal sensor. For instance, if your body is sweating, the Cliff will open the zipper automatically. Besides that, the Cliff should also be an active system to deal with different thicknesses of the fabrics.

- The third essential factor which is the *Ease of Use* must be further developed. Every function intended for daily use must consume less than two seconds access (Starner et al., 1999).

All these three factors have different outcomes depending on who is going to use Cliff's. Therefore, defining the users and involving them even more via participatory design methods is going to be the next step. We hope that Cliff and these shared tools and insights enlarge the social engagement of the fashion industry by product innovation.

## ACKNOWLEDGEMENT

The authors would like to express their gratitude and special acknowledgements to the Ministry of Higher Education Malaysia (MoHE) and Universiti Malaysia Pahang (UMP) for the Ph.D programs funding of Mohamad Zairi Baharom. Also for staff members of D.Search lab, Department of Industrial Design, Eindhoven University of Technology and by-wire.net, for their kind support during the fabrication process of the robotic zipper prototype.

## References

- Ansun Multitech. (2015), "The History of Zipper", available at: <http://www.ansun.com/> (accessed 19 November 2015).
- Baharom, M.Z., Delbressine, F. and Feijs, L. (2016), "Kinematics Analysis of A Robotic Zipper Prototype For Miniaturization", *International Journal of Mechanical Engineering and Robotics Research*, Vol. 5 No. 4, pp. 305–310.
- Balon, D. (2011), "Facts about Myotonic Muscular Dystrophy", *Muscular Dystrophy Association*, No. December, available at: <http://mda.org/disease/myotonic-muscular-dystrophy/causes-inheritance>.
- DeLong, M.R. (1998), *The Way We Look : Dress and Aesthetics*, 2nd Editio., Fairchild Publications, New York.
- Dunne, L. (2010), "Smart Clothing in Practice: Key Design Barriers to Commercialization", *Fashion Practice The Journal of Design Creative Process & the Fashion Industr*, Vol. 2 No. 1, pp. 41–66.
- Dunne, L., Ashdown, S. and Mcdonald, E. (2002), "'Smart Systems': Wearable Integration of Intelligent Technology", *Proceedings of the International Centre of Excellence for Wearable Electronics and Smart Fashion Products (ICEWES) Conference.*, Cottbus, Germany.
- Dunne, L., Profita, H. and Zeagler, C. (2014), *Social Aspects of Wearability and Interaction, Wearable Sensors: Fundamentals, Implementation and Applications*, Elsevier Inc.
- Dunne, L.E., Profita, H., Zeagler, C., Clawson, J., Gilliland, S., Do, E.Y. i L. and Budd, J. (2014), "The social comfort of wearable technology and gestural interaction", *Annual International*

- Conference of the IEEE Engineering in Medicine and Biology Society.*, Vol. 2014, pp. 4159–4162.
- Dunne, L.E. and Smyth, B. (2007), “Psychophysical Elements of Wearability”, *CHI’ 07- Conference on Human Factors in Computing Systems, Vols 1 and 2*, pp. 299–302.
- Gemperle, F., Kasabach, C., Stivoric, J., Bauer, M. and Martin, R. (1998), “Design for wearability”, *Digest of Papers. Second International Symposium on Wearable Computers. IEEE.*, pp. 116–122.
- Holst Centre. (2016), “Holst Centre 10th Anniversary Symposium”, available at: <https://www.holstcentre.com/> (accessed 7 April 2016).
- Howe, E. (1851), “Improvement in Fastenings for Garments”, *US Patent No. 8540*.
- Judson, W.L. (1893), “Shoe-fastening”, *US Patent No. 504037*.
- Knight, J., Baber, C., Schwirtz, A. and Brostow, H. (2002), “The Comfort Assessment of Wearable Computers”, *6th International Symposium on Wearable Computers (ISWC’02)*.
- Kuusk, K., Tomico, O. and Langereis, G. (2012), “Crafting Smart Textiles – a meaningful way towards societal sustainability in the fashion field?”, *The Nordic Textile Journal*, Vol. 1, pp. 7–15.
- Liever Thuis. (2015), “Liever Thuis : voor comfortabel en slim wonen”, available at: <http://lieverthuis.info/> (accessed 24 December 2015).
- Mady, N.I. and Atiha, S.M. (2015), “Taking Advantage of Ergonomics in Clothing Design to Improve Quality of Life for People with Parkinson ’ s Disease”, *Canadian Symposium XIII on Home Economics / Home Ecology / Family Studies Education*, pp. 60–69.
- Marriott, R. (2012), *Meccano*, Shire Books, Colchester, United Kingdom.
- McEwen, C. (2016), “Personal Communication on The Cliff Prototype, At Holst Centre 10th Anniversary Symposium, Amsterdam, 14th April 2016, Sales and Business Development of ShinEtsu Micro5i”.
- Pan, Y., Blevis, E. and Kong, H. (2014), “Fashion Thinking : Lessons from Fashion and Sustainable Interaction Design , Concepts and Issues”, *Proceedings of the 2014 Conference on Designing Interactive Systems.*, ACM, pp. 1005–1014.
- Price, M.C. and Lewis, C.M. (2015), *Developing a Strategy for the Effective Specification of Functional Clothing with Integrated Wearable Technology, Textile-Led Design for the Active Ageing Population*, Elsevier, available at:<https://doi.org/10.1016/B978-0-85709-538-1.00022-5>.
- Seymour, S. (2008), *Fashionable Technology: The Intersection of Design, Fashion, Science, and Technology*, Springer.
- Shaw, R. and Grall, C. (2003), *Great Inventors and Inventions*, Wizard Books.

- Smart Homes. (2015), “Smart Home Beurs Domotica and Slim Wonen”, available at:  
<http://www.beursdomoticaenslimwonen.nl/beursdomotica/Bezoekers.aspx> (accessed 20 December 2015).
- Starner, T., Drive, A., Rhodes, B., Weaver, J. and Pentland, A. (1999), “Everyday-use Wearable Computers”, *Georgia Tech Technical Report*.
- Sundback, G. (1917), “Separable Fastener”, *US Patent No. 1219881*.
- Toeters, M. (2015), “Personal Communication on The Second Iteration Prototype, 05th November 2015”.
- Toeters, M. (2016), “Personal Communication on The Third Iteration Prototype, 18th March 2016”.
- Toeters, M., ten Bhömer, M., Bottenberg, E., Tomico, O. and Brinks, G. (2012), “Research through Design: A Way to Drive Innovative Solutions in the Field of Smart Textiles”, *Advances in Science and Technology*, Vol. 80, pp. 112–117.
- Toeters, M. and Feijs, L. (2014), “Actuating Movement in Refined Wearables”, *Global Fashion 2014: International Fashion Conference, Ghent Belgium*, pp. 1–15.
- Vasluian, E., Wijk, I. Van, Dijkstra, P.U., Reinders-messelink, H.A. and Sluis, C.K. Van Der. (2014), “Adaptive Devices in Youngsters with Upper Limb Reduction Deficiencies: Use and satisfaction”, *Journal of Rehabilitation Medicine*.
- Vitalis. (2016), “Care Group”, available at: <http://www.vitalisgroep.nl/> (accessed 16 August 2016).
- Walker, S. (2012), *Sustainable by Design: Explorations in Theory and Practice*, Earthscan, London.
- Wasowska, M. (2016), “Personal Communication on The Cliff Prototype, At Holst Centre 10th Anniversary Symposium, Amsterdam, 14th April 2016, Divisional Director (Technology and Software Centre of SONY Europe)”.
- Whiton, A. (2015), “Methods and Apparatus for Robotic Zipper”, *US Patent No. 2015/0082582A1*.
- Zipf, G.K. (1949), *Human Behavior and the Principle of Least Effort: An Introduction to Human Ecology*, Addison-Wesley.
- Zorriassatine, F., Wykes, C., Parkin, R. and Gindy, N. (2003), “A survey of virtual prototyping techniques for mechanical product development”, *Proceedings of the Institution of Mechanical Engineers, Part B: Journal of Engineering Manufacture*, Vol. 217 No. 4, pp. 513–530.